



# Sound-Loc™

Airgun Noise Reduction  
System Installation Kit



## WARNING

This kit is for use in AirForce airguns only. Do not attempt installation in any other device. Misuse may result in serious injury or death.

**READ ALL INSTRUCTIONS  
AND WARNINGS BEFORE  
RE-USING THIS AIRGUN.**



# WARNING

Make sure the gun is unloaded and tank removed before performing any maintenance or modifications.

Make sure the gun is not cocked.

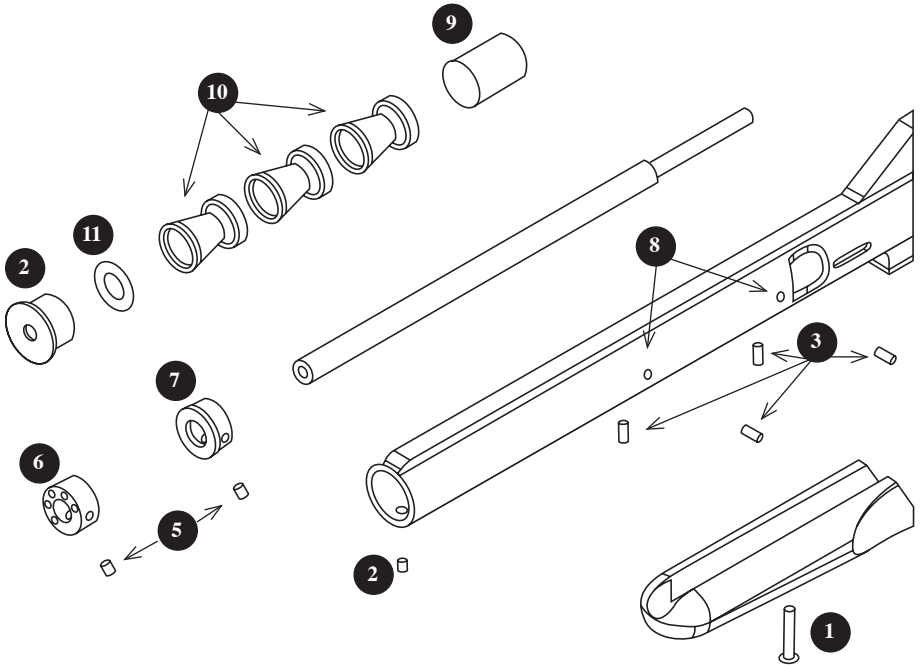

- 1) Remove the forearm by removing the forearm screw. **1**
- 2) Remove the muzzle cap by removing the muzzle cap screw and pulling the muzzle cap from the end of the frame. **2**
- 3) Remove the side and bottom barrel screws. **3**
- 4) Remove the barrel assembly from the front of the frame. If the barrel is hard to remove it may require you to push it from the breach end.  
*Note: if you have to push the barrel, use something that will not damage the breach of your barrel when pushing through the bolt. Also note that a neoprene washer and a white Teflon O-ring may come out with your barrel assembly. Be sure to replace them when you reinstall your barrel assembly.*
- 5) Remove the barrel bushings from the barrel by removing the barrel bushing screws. **5**

- 6) Install the new Sound-Loc sealed barrel bushing by sliding it onto the barrel first, making sure that the O-rings are toward the muzzle end. 6
- 7) Install the vented barrel bushing on the barrel. 7
- 8) Reinstall the barrel assembly. It is best to try and line up the barrel screw holes in your frame and barrel bushings before pushing the new barrel assembly into position. 8
- 9) Slide the baffle spacer into the muzzle end of the frame as shown below. 9
- 10) Slide the baffles into the muzzle end of the frame with the small interrupted cone as shown below. 10
- 11) Install the spring washer on the muzzle end as shown below. 11

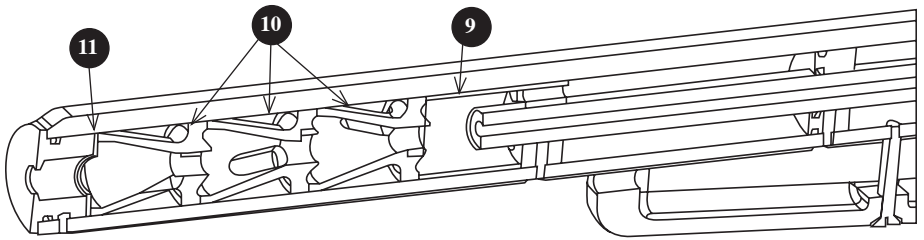

*Installation of spacer, baffles and spring washer.*

- 12) Reinstall the muzzle cap and secure it in place with the muzzle cap screw. 2
- 13) Reinstall the forearm. 1

## Airgun Safety

Airguns are unique because the gun provides the power for the shot—not the ammunition. **NEVER** put anything into the barrel of this airgun except high quality lead pellets.

### Three Important Rules

1. Always point the muzzle in a direction that will not cause injury or property damage if the gun discharges.
2. Keep your finger off the trigger until you are ready to shoot.
3. Don't load the gun until you are ready to shoot.

**NOTICE: READ ALL INSTRUCTIONS BEFORE  
INSTALLATION OR RE-USING THIS AIRGUN**



[www.airforceairguns.com](http://www.airforceairguns.com)

877-247-4867 • 817-451-8966 • (fax) 817-451-1613

P.O. Box 2478 • Fort Worth, TX 76113

*Photographs, drawings, descriptions and other information are purely indicative.  
AirForce reserves the right to change, modify or discontinue products or features at any time.*

*Rev. 04/13*