



Spin-Loc™ System Instructions

AirForce Airguns
P.O. Box 2478
Fort Worth, TX 76113
817-451-8966
Fax: 817-451-1613
www.airforceairguns.com



WARNING: Ma
before installing or removi



CAUTION: Fra
the Spin-Loc System to ins

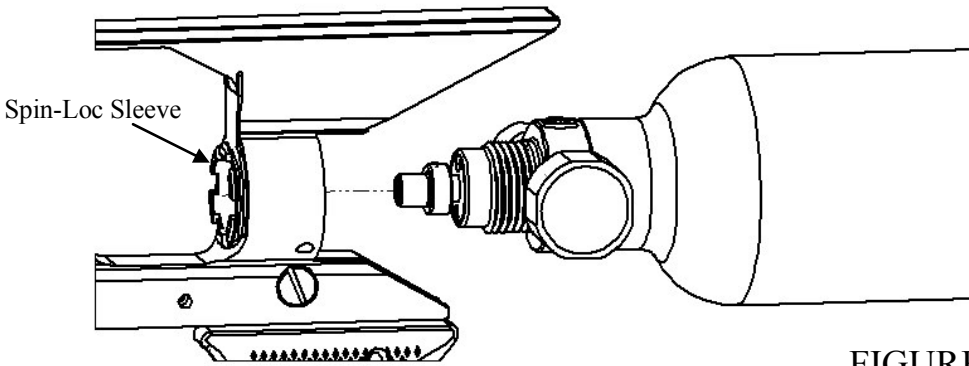

FIGURE 1

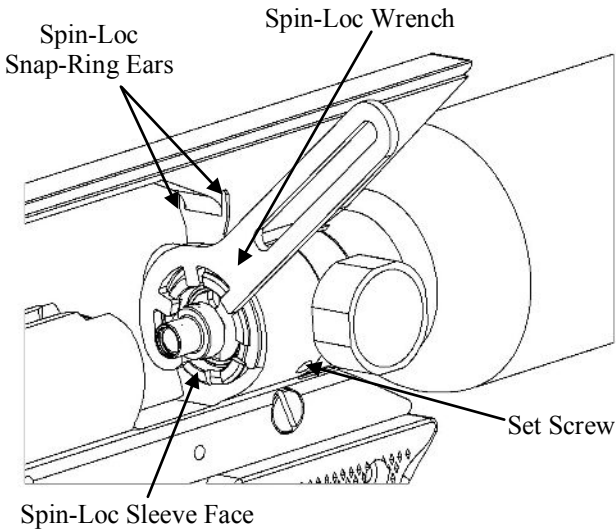

FIGURE 2

**Make sure gun is unloaded
before attaching an air tank.**

**Some models must be equipped with
tall Spin-Loc air tanks.**

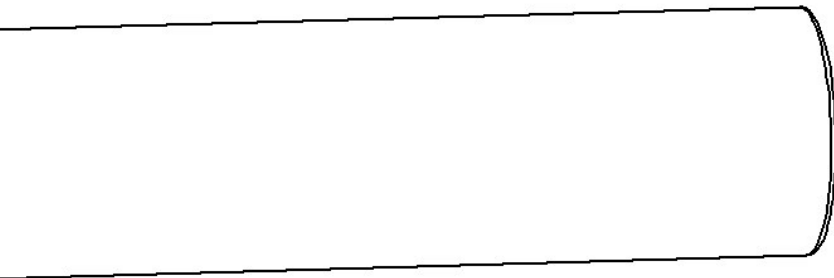

FIGURE 1

- 1: Slide the air tank into the rear of the frame. See FIGURE 1.
- 2: Screw the Spin-Loc Sleeve onto the air tank until it is hand tight. Make sure that the Set Screw is loose and allows the Spin-Loc Sleeve to turn freely. See FIGURE 2.
- 3: Use the Spin-Loc Wrench to tighten the air tank in place. Use **CARE** so you will not scratch your aluminum Frame. See FIGURE 2

NOTE: If you have a Quick-Detach Air Tank, without the gauge and refill fitting, tighten the set screw to keep the Spin-Lock Sleeve from turning. Then screw in your Quick-Detach Tank as you normally do in a standard frame.

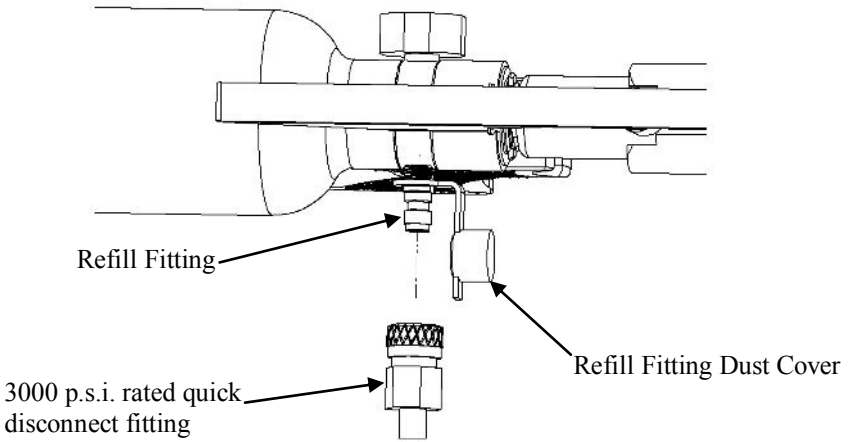

FIGURE 3

To refill your Spin-Loc Tank, attach the 3000 p.s.i. rated quick disconnect to the refill fitting. See FIGURE 3.