



TalonP Owner's Manual



WARNING: This airgun is recommended for adult use only. Careless use may result in serious injury or death. Dangerous within 510 yards (470 meters). Capable of velocity in excess of 1,000 feet per second (305 m.p.s.)

Read all instructions before using this pistol

This airgun should only be used by responsible persons 18 years or older.

Use lead pellets only.

Contents

Warnings	1-2
Manufacturer's Contact Information	2
Specifications	3
Nomenclature	4
1. Safety First	5
2. Filling the air tank	5
3. Attaching the air tank to the pistol	6
4. Cocking, uncocking, loading and firing	7
5. Adjusting power	8
6. Operational tips	9
7. Maintenance of the air tank and care during shipping.....	10
8. Safe shooting	10
9. Troubleshooting.....	11-12



WARNING: Use compressed air, dry nitrogen, or carbon dioxide only. Use of other gases may cause the tank to rupture causing serious injury or death.



WARNING: Always wear eye protection when using this airgun. This includes everyone in the area where shooting is taking place.



WARNING: Modifications to this air gun beyond user adjustments specifically outlined in this manual are not authorized. Any modification or tampering with the gun may cause malfunction and make the gun unsafe for use.



WARNING: Remove the air tank before making any adjustments, performing any maintenance or adding/removing any accessories.

For repairs contact the manufacturer. You will be given instructions how to return the pistol to the factory or other authorized repair station.

AirForce

P.O. Box 2478, Fort Worth, TX 76113
Tel 817-451-8966 Fax: 817-451-1613
staff@airforceairguns.com

Use of air with the TalonP pistol

This TalonP air pistol is designed for use with clean, dry compressed air, nitrogen, or carbon dioxide. The maximum fill pressure is 3,000 pounds per square inch (psi), which is 206 bar. A pressure relief device has been installed in the air tank and can rupture if the internal pressure exceeds 3,000 psi/206 bar.

All AirForce airguns have precision rifled barrels. They will shoot accurately only with good quality lead pellets of the appropriate caliber.

The use of any projectile other than a lead pellet is unauthorized and will void the warranty.



TalonP Specifications

Velocity	400-900 f.p.s., depends on pellet weight and power setting
Fill pressure	3,000 psi/ 206 bar (only use compressed air or dry nitrogen)
Weight	3.5 lbs.
Length	24.2 inches
Barrel	12 inches
Action	Single-shot
Caliber	.25
Trigger	2-stage sporting trigger
Safety	Automatic on cocking
Air tank	213 cc
Sights	Open or optical may be installed

Nomenclature

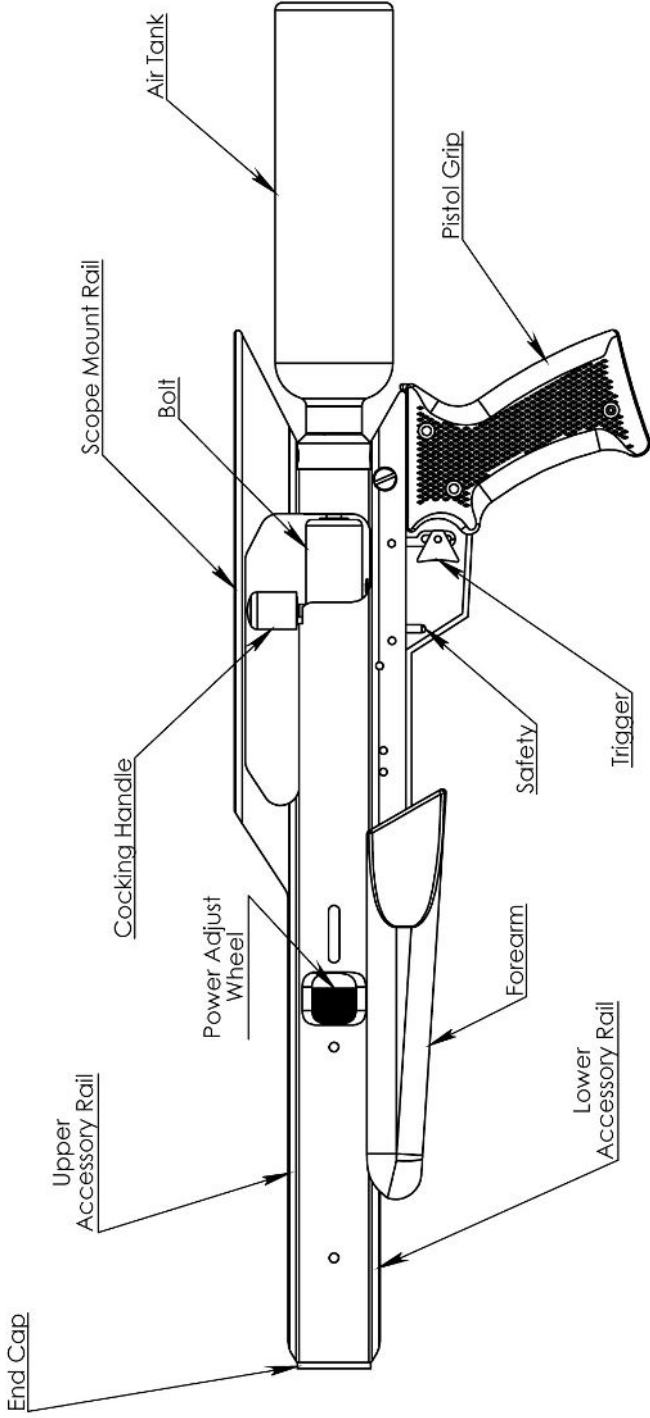

1. Safety First!

Any gun is dangerous when handled improperly, including an airgun. AirForce airguns are especially powerful, so they must be taken seriously at all times. Review the three safety rules that follow, plus the special warnings that appear throughout this manual.

1.1 Airgun safety

Airguns are unique because the gun provides the power for the shot—not the ammunition. NEVER put anything into the barrel of this airgun except high quality lead pellets.

1.2 Three important rules

1. Always point the muzzle in a direction that will not cause injury or property damage if the gun discharges.
2. Keep your finger off the trigger until you are ready to shoot.
3. Don't load the gun until you are ready to shoot.

2. Filling the air tank

Refill Clamp

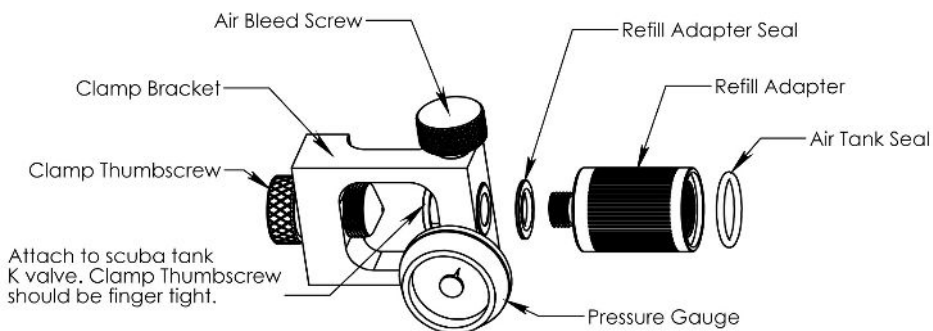

2.1 The refill clamp

If you fill from a scuba tank that has a K-valve, the AirForce refill clamp is the way to connect your air tank. The square clamp attaches to the K-valve and mates with the O-ring in the scuba tank valve. Once the refill clamp is attached to the scuba tank, close the bleed screw and screw the air tank into the adapter.

2.2 Filling from a scuba tank

With the refill clamp attached to the scuba tank and the rifle's air tank attached to the refill clamp, open the scuba tank valve very slowly. Allow at least one minute for the tank to fill, which you can watch on the gauge. Do not exceed 3,000 pounds per square inch/206 bar. When the fill is complete, close the scuba tank valve.

To disconnect the air tank from the refill clamp, open the bleed screw. This allows the high pressure air inside the refill clamp to exhaust, making it possible to unscrew the air tank.

Leave the refill clamp on the scuba tank or put it in a box. Either way, keep the clamp assembly as clean as possible.

3. Attaching the air tank to the pistol

To install the tank, push forward on the cocking knob lightly to move the bolt out of the tank's way. It may help to point the muzzle of the gun toward the ground as you connect the tank. The fast-twist threads make tank installation quick and easy, once you have done it a few times.

4. Cocking, uncocking, loading, firing

To cock the pistol, push forward on the cocking knob until the bolt is held in the open position. The automatic safety will engage at this time.

To load a pellet, cock the pistol and leave the bolt forward, exposing the breech. Push a pellet ALL THE WAY into the breech with your thumb or a pellet-seating tool. This is important, because a pellet not pushed in all the way can hold the valve open when the pistol fires, exhausting all the air from the tank.

After loading, slide the bolt all the way back and rotate it into either notch at the rear of the cocking slot. This indicates the bolt is all the way back.

To fire, take aim, release the safety and squeeze the trigger until the pistol discharges.

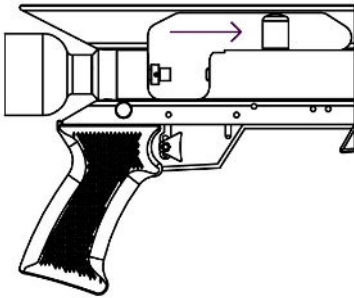

Cock the pistol by pushing forward on the cocking knob until the bolt clicks and stays open like this. The safety has also set automatically. You can now load one pellet into the back of the barrel, making sure to push it as far into the barrel as possible.

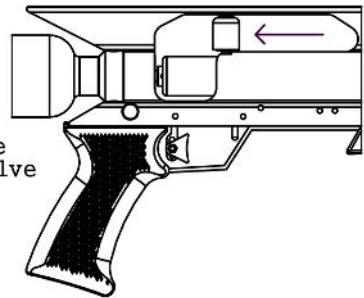

When the pellet has been loaded, pull the bolt all the way back so it covers the valve like this. Then rotate the cocking knob either left or right into the notch.



WARNING: Do not release the safety unless the air gun is pointed in a safe direction. Safe means that if the gun discharged it would not cause injury or property damage. Mechanical safeties are not infallible and do not replace the need for responsible gun handling practices.

5. Adjusting power

Power can be adjusted with the power adjust wheel. Power does not adjust evenly as the numbers increase and decrease. Rather, there are zones at which the power settles into a velocity range. For the most precise settings, use a chronograph when adjusting power and note what setting gives what velocity with a particular pellet.

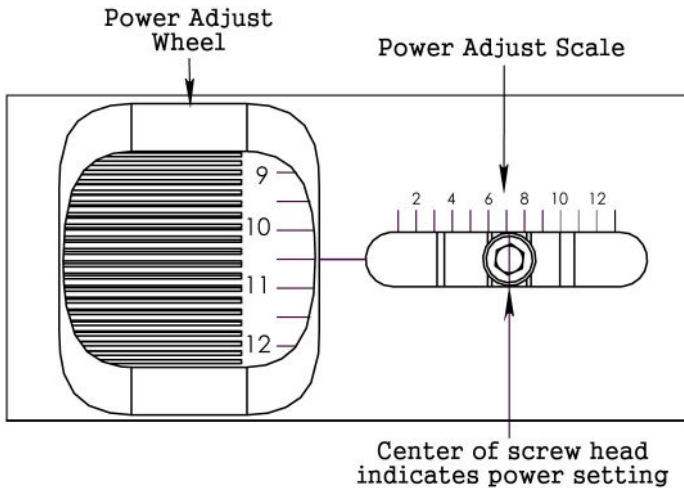

TalonP

The TalonP is made for power. It will shoot heavy pellets faster than most air rifles. When you shoot the heaviest pellets, you can dial the power up all the way and the rifle will be capable of great power with fine accuracy.

You can get about 10 shots at the highest power setting, and up to 20 shots if you are willing to accept a broader velocity range. The thing to do is shoot the airgun at perhaps 20 yards or more, and see how many shots will group well before the lowering velocity starts to lower the impact point of the pellet.

The TalonP can also be dialed down in power and still shoot light to medium weight pellets quite fast.

6. Operational tips

6.1 Power adjustments

The pistol needs one shot to settle down following a power adjustment. After that, it should give shots at a consistent velocity.

6.2 Removing or disabling the safety mechanism

The automatic safety mechanism relies on the movement of trigger parts. Disabling or removing any of the safety parts can disable the pistol and will void the warranty.

6.3 Modifications to the valve

The valve in the AirForce Pistol is not a user-maintainable item. Any attempt to remove or modify the valve in any way will void the warranty.

6.4 Filling the air tank with a gas other than air, dry nitrogen or carbon dioxide

This practice is not recommended and voids the warranty for the pistol.

6.5 Cleaning the barrel

An airgun barrel seldom needs cleaning. If you do clean the barrel, use a good quality bore brush of the correct size and use a non-jointed cleaning rod if possible. Do not use cleaning solvents and agents formulated for firearms because they can attack the seals and O-rings, rendering the pistol inoperative.

6.6 Removing jammed pellets from the barrel

Remove the air tank. Remove the end cap to see the true muzzle of the barrel. Always attempt to remove jammed pellets from the breech through the muzzle; only go from the muzzle end if there is no other way. Use a good cleaning rod of the correct size to push the jam out the muzzle.

7. Maintenance of the air tank and care during shipping

AirForce airguns have an air tank pressurized to 3,000 psi when full. This tank is designed to be filled at all times. You can leave it pressurized to 3,000 psi indefinitely, or you can keep a lower “caretaker” charge of around 2,000 psi in the tank; if you desire.

The air tank is equipped with a safety burst disk that will rupture if the internal pressure gets too high. Under no circumstances should the tank be pressurized beyond 3,000 psi.

To empty the air tank, use the black steel fill adapter that comes with both the AirForce refill clamp and the AirForce pump. It is a separate part and should be separated to perform this operation. Insert one or two dimes in the fill adapter, then screw it on the air tank. As the threads bring the tank and adapter together, the valve will contact the dime(s). Continuing to screw the adapter on the tank will open the valve, exhausting the air inside. Allow this to take as much time as possible, because a rapid exhaust will chill the tank and cause condensation inside. When the tank is completely empty it is safe to ship by any commercial means.

8. Safe shooting

All AirForce airguns are extremely powerful and should always be used with a safe backstop. If you are shooting paper targets, a firearm-safe bullet trap is adequate, as long as precautions are taken for safety if the trap is ever missed. We recommend you use a trap that will stop a bullet from a .22 long rifle cartridge fired from a rifle.

Never point the muzzle of the pistol at anything you do not intend to shoot. Make this a habit, so you handle an empty airgun the same way all the time. If you handle all guns this way, you will protect yourself and others if there should be an accidental discharge at some time.

Pellets from all AirForce airguns will explode into dust and fragments when they hit a hard surface like a steel backer plate in a bullet trap. Always wear safety glasses when shooting into a hard bullet trap.

If you use a “silent” pellet trap with the pistol, make sure the trap has at least two inches of ballistic putty with a steel backed plate behind it. The pistol should never be shot at a “silent” trap made for airgun use.

In the field, avoid targets that will make the pellet ricochet. These can be both hard targets like plywood, trees and the sides of structures to water, snow, ice or the ground when struck at a shallow angle.

9. Troubleshooting

9.1 Gun fails to fire when the trigger is pulled

Is the gun cocked?

Has the safety been taken off?

Is the removable air tank installed?

Is the tank filled with air?

Is anything blocking the valve or the bolt?

Was the bolt closed and rotated to one side before firing?

Is the air tank overfilled, causing valve lock?

9.2 Air is leaking from the tank

Install the air tank on the pistol. And fire several times without a pellet.

If air continues to leak after this has been tried, it will have to be repaired at the factory.

9.3 Gun fires but pellet remains in the barrel

Is the air tank filled?

Is the barrel free from obstructions?

Was the bolt closed and turned to one side when you fired?

Is the pellet of the correct caliber for the barrel?

Are you sure the pellet did not exit the barrel? Remove the air tank and look through the rear of the barrel to verify that it is still inside.

9.4 Gun fires with widely varying velocity

Are all the pellets the same?

Are the pellets high quality?

Are you using lead pellets? Synthetic pellets deposit residue in the barrel that can cause velocity variation.

Are the pellets the correct caliber?

Is the air tank filled to 3,000 psi? As the tank drops to 2,000 psi, velocity will start to vary more.

Is the barrel dirty?

Are you shooting the gun with the power adjuster below the number 3? At those settings, the velocity will vary more—especially if the air tank is low.

9.5 When the gun fires, all the air exhausts from the tank

The cause for this is almost always a pellet that was not seated properly into the breech. The skirt is blown against the breech face when high pressure air first hits it and it creates a high pressure air seal that forces the valve to remain open.

9.6 Air leaks from the refill clamp when filling the air tank

Is the refill clamp bleed valve closed?

Is the refill clamp fitted squarely to the O-ring in the scuba tank I-valve?

Is the refill clamp thumbscrew tight?

9.7 The hand pump doesn't seem to fill the air tank

Is the tank screwed tightly to the adapter on the pump? Are all the adapter seals installed?

Is the brass bleed screw on the pump base closed?

It can be difficult to determine that the hand pump is filling the air tank when the tank is empty. Air tanks are shipped empty to comply with the law. An empty air tank doesn't SEEM to be filling when you pump the pump. Actually it takes about 75 pump strokes before you notice that the needle on the pump's gauge is slightly above zero. Once the tanks starts to register a charge, you will notice that it takes 14 or 15 pump strokes to raise the tank pressure by 100 psi. That's true at all pressure levels.

AirForce warranty for airguns sold in the United States

Mailing the enclosed warranty card within 60 days of purchase entitles the original buyer to a warranty covering defects in material and workmanship for the life of the airgun. Any AirForce airgun covered by this warranty will be repaired or replaced at the discretion of AirForce, should a defect in material or workmanship be found. Normal wear parts such as O-rings and seals, are not covered.

Repairs may only be made by the factory or an authorized service station. This lifetime warranty becomes invalid for any gun that is disassembled or modified in any way not specifically authorized by the factory. This lifetime warranty also becomes invalid for any gun that has been damaged by abuse or improper handling. For shipping instructions for warranty service call 1-877-247-4867. This warranty is not valid for guns used in governmental or commercial applications. A one-year warranty applies in those instances.

