



AIRFORCE
a i r g u n s

**Texan[®], TexanSS, TexanLSS
& Texan Carbine Rifle
Safety & Operation Manual**



WARNING

This airgun is recommended for adult use only. Careless use may result in serious injury or accidental death.

Dangerous within a minimum of 1 mile (1610 meters).

Capable of velocity in excess of 1,000 feet per second (305 m.p.s.)

This air rifle should only be used by responsible persons 18 years or older.

Use airgun ammunition only.

**READ ALL INSTRUCTIONS
AND WARNINGS BEFORE
USING THIS AIRGUN.**

⚠ WARNING: The Texan/TexanSS/TexanLSS/Texan Carbine are capable of generating over 800 ft. lbs. of energy.

Only shoot with a backstop rated for 800 ft. lbs. or greater.

⚠ WARNING: This air rifle is not a toy and can cause serious injury or death.

CAUTION: The airgun should be used only by adults or under adult supervision.

NOTICE: Always wear eye and ear protection when using this airgun. This includes people in the immediate vicinity.

⚠ WARNING: Always assume the air rifle is loaded. Never leave the airgun loaded if it is not going to be used.

⚠ WARNING: Always point the air rifle in a safe direction and be aware of the backstop.

⚠ WARNING: Do not point at anything you do not intend to shoot.

⚠ WARNING: Do not fire at a target that allows ricochets or deflections. Do not fire into or at water.

NOTICE: Be certain that the airgun ammunition you use is in the proper caliber for the airgun. Never re-use projectiles.

⚠ WARNING: Airgun ammunition contains lead. Follow all airgun ammunition package safety directions. Wash hands thoroughly after handling. Do not put in mouth.

CAUTION: Store the airgun (unloaded) and airgun ammunition in separate, safe places, out of reach of children.

⚠ WARNING: Do not walk, jump or run when carrying a loaded air rifle. Keep your fingers away from the trigger and do not load the rifle until you are ready to fire.

CAUTION: Unload the airgun before putting it in a vehicle.

NOTICE: Do not remove from its case or show the air rifle in public.

NOTICE: Buyer and user have the duty to obey all laws about the use and ownership of this airgun.

⚠ WARNING: Anytime you carry or transport an airgun, make sure the safety is on and the gun is unloaded. Under no circumstances carry or transport when loaded.

⚠ WARNING: Do not fill the air cylinder above recommended fill pressures marked on cylinder. The resulting damage caused by overcharging the bottle is not covered by the manufacturer's warranty.

⚠ WARNING: Only use dry-filtered, compressed air or nitrogen to fill the air cylinder. Never use other gases such as oxygen, acetylene, hydrogen, etc.

NOTICE: It is recommended that you have the air tank visually inspected every 3 years and a hydrostatic test every 5 years.

FAILURE TO OBSERVE THE ABOVE WARNINGS & CAUTIONS CAN RESULT IN DAMAGE TO YOUR AIR RIFLE, ACCIDENTAL DEATH OR SERIOUS INJURY. SAFE SHOOTING IS EVERYONE'S RESPONSIBILITY

For repairs contact the manufacturer. You will be given instructions how to return the airgun to the factory or other authorized repair station.

AirForce • P.O. Box 2478, Fort Worth, TX 76113
817-451-8966 • Fax: 817-451-1613 • staff@airforceairguns.com

Use of Air With the Air Rifle

AirForce air rifles are designed for use with clean, dry compressed air or nitrogen. The maximum fill pressure for Aluminum bottles is 3,000 pounds per square inch (psi), which is 206 bar. A pressure relief device has been installed in the air tank and can rupture if the internal pressure exceeds 3,000 psi/206 bar. The maximum fill pressure for carbon fiber bottles is 3,625 pounds per square inch (psi), which is 250 bar. A pressure relief device has been installed in the air tank and can rupture if the internal pressure exceeds 3,625 psi/250 bar.

All AirForce airguns have precision rifled barrels. They will shoot accurately only with good quality lead airgun ammunition of the appropriate caliber.

The use of any projectile other than lead is unauthorized and will void the warranty.

Safety First!

Any gun is dangerous when handled improperly, including an airgun. AirForce airguns are especially powerful, so they must be taken seriously at all times. Review the safety rules on the preceding page, plus the special warnings, cautions and notices that appear throughout this manual.

Airgun Safety

Airguns are unique because the gun provides the power for the shot—not the ammunition. NEVER put anything into the barrel of this airgun except high quality lead airgun ammunition.

Three Important Rules

1. Always point the muzzle in a direction that will not cause injury or property damage if the gun discharges.
2. Keep your finger off the trigger until you are ready to shoot.
3. Don't load the gun until you are ready to shoot.

NOTICE: READ THIS MANUAL ENTIRELY BEFORE CHARGING OR USING YOUR AIRGUN

Specifications

Texan

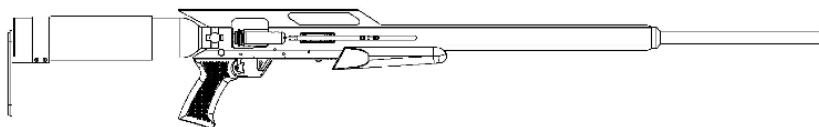

Power Adjustment	None, Self Adjusting
	User Tunable for different projectile weights
Max Fill Pressure	3000 psi Aluminum Cylinder/3625 psi Carbon Fiber Cylinder
Action.....	Single shot
Weight	8.0 lbs
Length	48.0 inches
Barrel.....	34 inches
Caliber.....	0.257, 0.308, 0.357, 0.457, 0.50
Trigger.....	2 stage, adjustable for position
Safety	Automatic on cocking
Air Tank Volume	490cc
Velocity	In excess of 1100 feet per second
	(Depending on caliber, airgun ammunition weight, and tuner setting)
Sights.....	Open or optical may be installed
Energy	up to 750 foot pounds
	(Depending on caliber, airgun ammunition weight, and tuner setting)

TexanSS

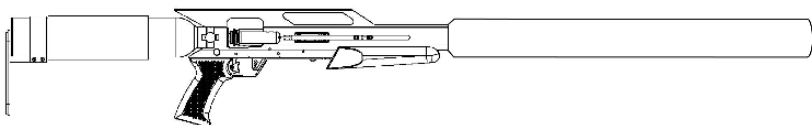

Power Adjustment	None, Self Adjusting
	User Tunable for different projectile weights
Max Fill Pressure	3000 psi Aluminum Cylinder/3625 psi Carbon Fiber Cylinder
Action.....	Single shot
Weight	8.45 lbs
Length	45.0 inches
Barrel.....	24.75 inches
Caliber.....	0.308, .0357, 0.457
Trigger.....	2 stage, adjustable for position
Safety	Automatic on cocking
Air Tank Volume	490cc
Velocity	In excess of 930 feet per second
	(Depending on airgun ammunition weight, and tuner setting)
Sights.....	Open or optical may be installed
Energy	up to 600 foot pounds
	(Depending on airgun ammunition weight, and tuner setting)

Note: Line drawings above are illustrative of model only and not intended to be accurate for scale or features.



WARNING: ALWAYS KEEP THE MUZZLE POINTED IN A SAFE DIRECTION

Specifications

Texan Carbine

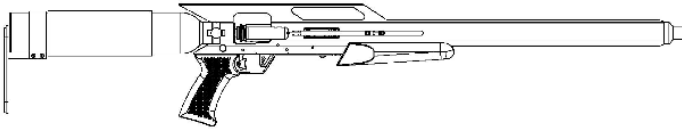

Power Adjustment	None, Self Adjusting
	User Tunable for different projectile weights
Max Fill Pressure	3000 psi Aluminum Cylinder/3625 psi Carbon Fiber Cylinder
Action.....	Single shot
Weight	7.5 lbs
Length	39.0 inches
Barrel.....	24.75 inches
Caliber.....	0.308, 0.357, 0.457
Trigger.....	2 stage, adjustable for position
Safety	Automatic on cocking
Air Tank Volume	490cc
Velocity	In excess of 930 feet per second
	(Depending on caliber, airgun ammunition weight, and tuner setting)
Sights.....	Open or optical may be installed
Energy	up to 600 foot pounds
	(Depending on caliber, airgun ammunition weight, and tuner setting)

TexanLSS

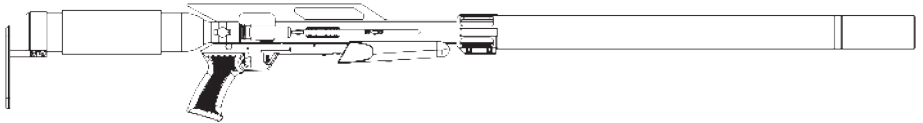

Power Adjustment	None, Self Adjusting
	User Tunable for different projectile weights
Max Fill Pressure	3000 psi Aluminum Cylinder/3625 psi Carbon Fiber Cylinder
Action.....	Single shot
Weight	9.3 lbs
Length	54.25 inches
Barrel.....	34 inches
Caliber.....	0.257, 0.308, .0357, 0.457, 0.50
Trigger.....	2 stage, adjustable for position
Safety	Automatic on cocking
Air Tank Volume	490cc
Velocity	In excess of 1100 feet per second
	(Depending on airgun ammunition weight, and tuner setting)
Sights.....	Open or optical may be installed
Energy	up to 750 foot pounds
	(Depending on airgun ammunition weight, and tuner setting)

Note: Line drawings above are illustrative of model only and not intended to be accurate for scale or features.

NOTICE: READ THIS MANUAL ENTIRELY BEFORE CHARGING OR USING YOUR AIRGUN

Nomenclature

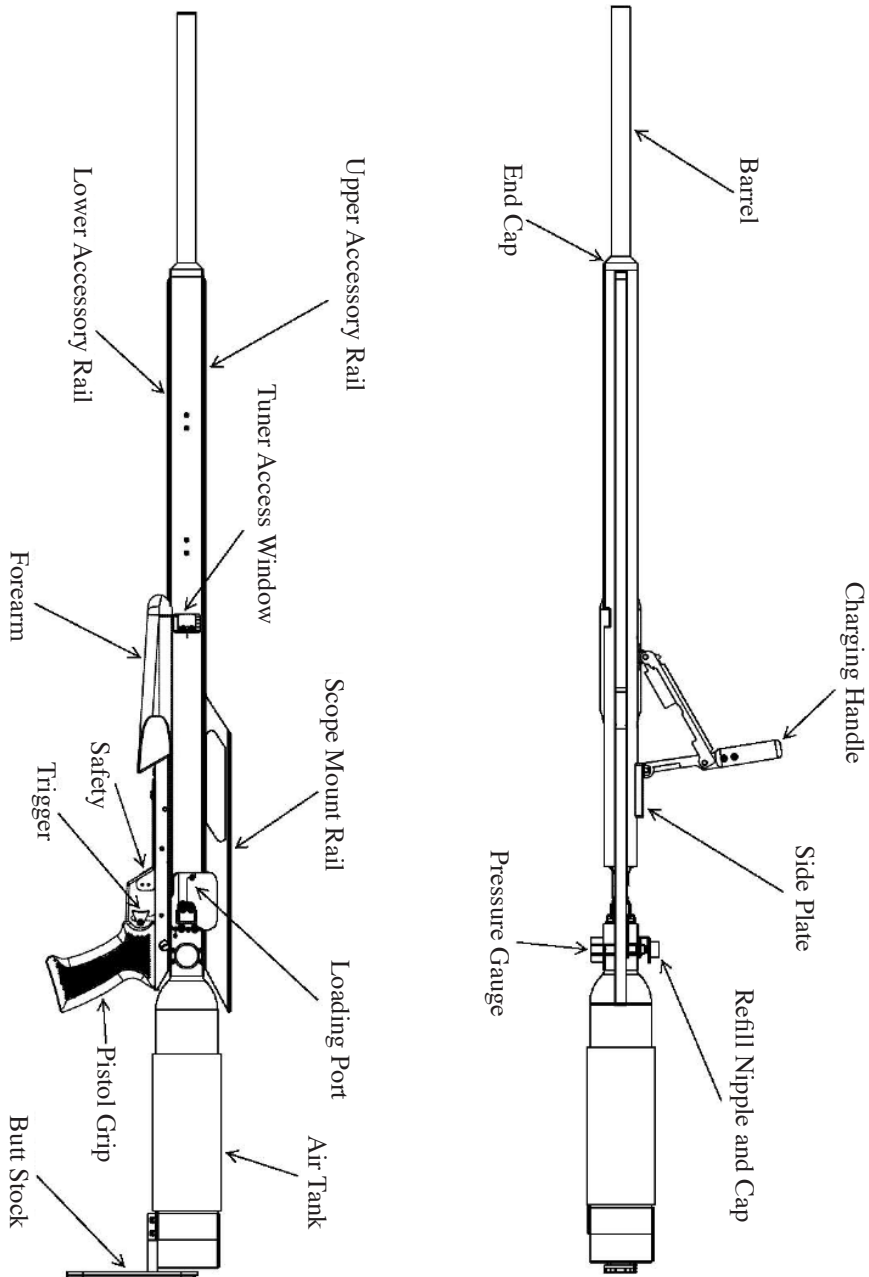



WARNING: ALWAYS KEEP THE MUZZLE POINTED IN A SAFE DIRECTION

Filling/Attaching the Air Tank

Spin-Loc™ Tank System

⚠ WARNING: Make sure air rifle is unloaded before installing air tank.

⚠ CAUTION: Dry firing without the Spin-Loc sleeve in place will damage the rifle.

Slide the air tank into the rear of the frame. See FIGURE 1.

Screw the Spin-Loc Sleeve onto the air tank until it is hand tight. Make sure that the Set Screw is loose and allows the Spin-Loc Sleeve to turn freely. See FIGURE 2.

Use the Spin-Loc Wrench to tighten the air tank in place. Use CARE so you will not scratch your aluminum Frame. See FIGURE 2.

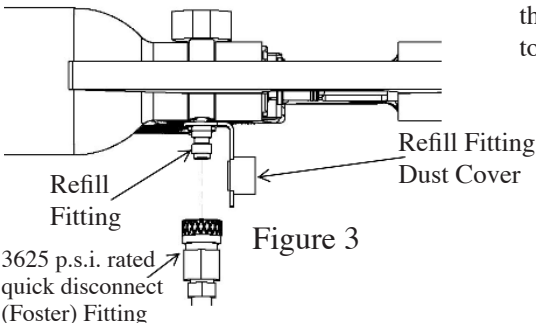
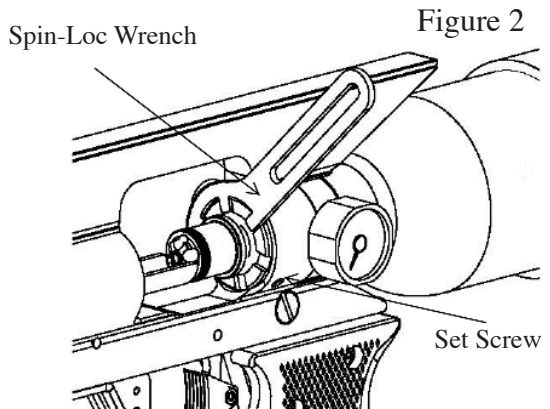
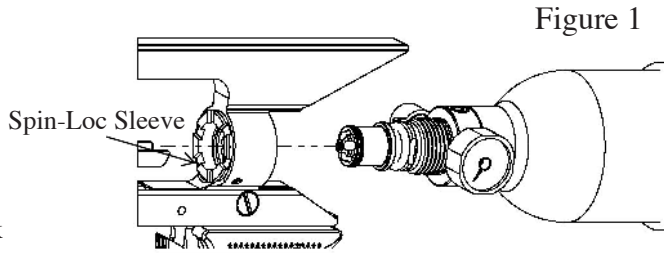

To refill your Spin-Loc Tank, attach the 3625 p.s.i. rated quick disconnect to the refill fitting. See FIGURE 3.

⚠ WARNING: BEFORE LOADING YOUR AIRGUN, MAKE SURE THE SAFETY IS IN THE ON SAFE POSITION AND THE MUZZLE IS POINTED IN A SAFE DIRECTION.

Loading, Cocking, Firing

Manually move the safety to the On Safe position by sliding safety lever back towards trigger.

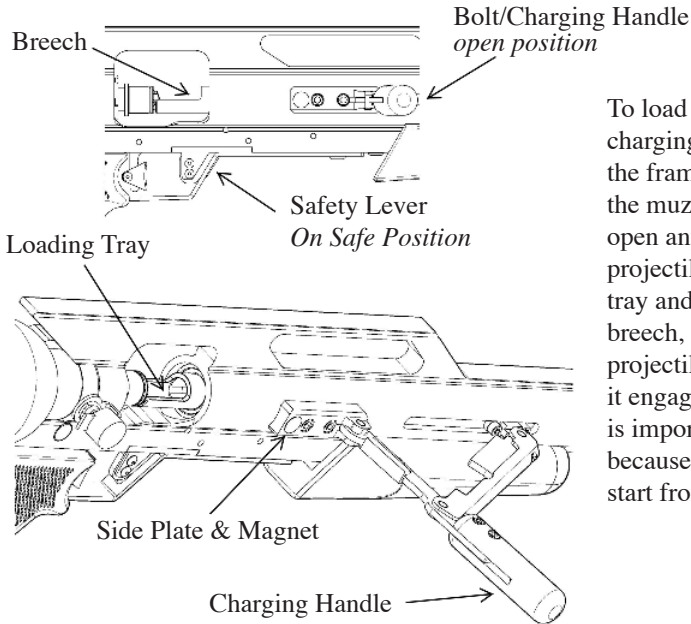

To load the rifle, pull the charging handle away from the frame and push it toward the muzzle until it cannot open any further. Place a projectile in the loading tray and push it into the breech, with your thumb or a projectile seating tool, until it engages the rifling. This is important for accuracy, because it makes each shot start from the same place.

After loading, pull the charging handle towards the rear of the gun, and push it in towards the frame, until the levers touch the side plate and magnet. This closes the breech and cocks the striker.

To fire, take aim, slide the safety to the On Fire position and squeeze the trigger until the rifle discharges.

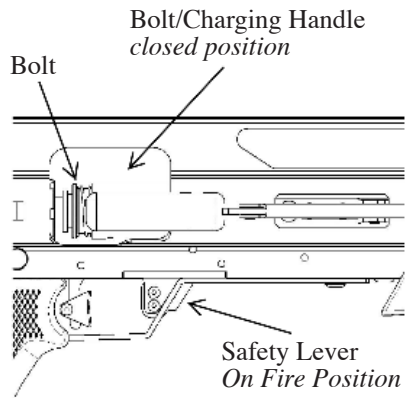

⚠ WARNING: DO NOT ATTEMPT TO FIRE YOUR AIRFORCE TEXAN AIR RIFLE IF THE TANK PRESSURE IS BELOW 2000 PSI. DOING SO MAY RESULT IN A SUDDEN RELEASE OF A HIGH VOLUME OF AIR, INCREASING RECOIL.



**WARNING: ALWAYS KEEP THE MUZZLE
POINTED IN A SAFE DIRECTION**

Adjusting the Tuner

To access the tuner, the action of your air gun must be fully open. At that point two windows on the left side of the frame will align, allowing access to the tuner.

The force of the striker can be adjusted so that there is just enough force to open the valve, eliminating excess wear and recoil. This also has shown accuracy improvements. Except for the lightest projectiles, once the valve is cracked open, the valve will self regulate to the weight of the projectile used. This is partially due to the fact that heavier projectiles have more contact to the bore and move slower out of the bore. The resulting pressure on the valve, holds it open longer. Very light-weight projectiles are the exception as they may not hold the valve open long enough to achieve maximum velocities. Starting at a lower tank pressure (i.e. 2700 p.s.i.) may help to achieve maximum accuracy with these light projectiles.

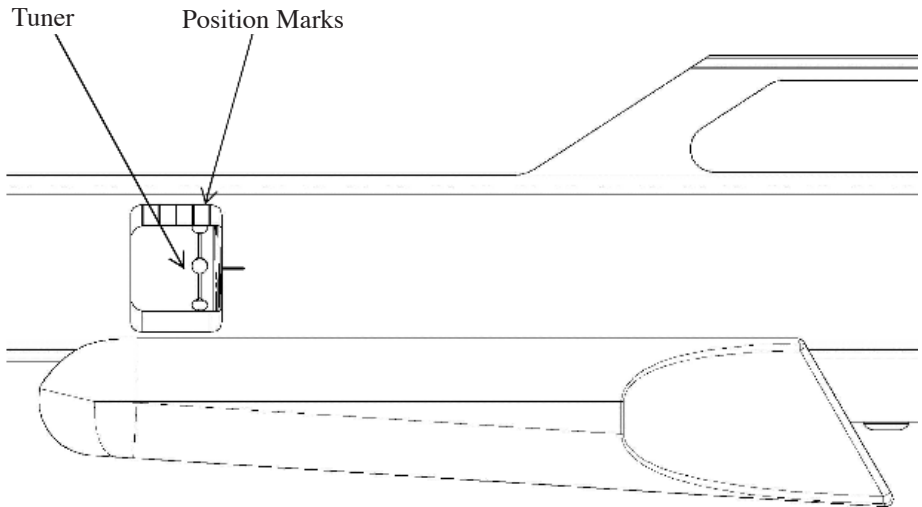

To increase tuner tension rotate it downwards, to decrease tension rotate it upwards. Increasing tension can help achieve higher velocities for light-weight projectiles.

Note: Position marks are only to help the shooter find and repeat settings when the rifle is tuned for a specific projectile.

NOTICE: READ THIS MANUAL ENTIRELY BEFORE CHARGING OR USING YOUR AIRGUN

Operational Tips

Removing or disabling the safety mechanism

Disabling or removing any of the safety parts can disable the rifle and will void the warranty and will create a hazardous condition.

Modifications to the valve

The valve in the AirForce rifle is not a user-maintainable item. Any attempt to remove or modify the valve in any way will void the warranty and may create a hazardous condition.

Filling the air tank with a gas other than dry compressed air or nitrogen

This practice is not recommended and voids the warranty for the rifle.

Cleaning the barrel

The Texan barrel may get lead fouling. If you need to clean the barrel, use a tight patch, wet with lead remover product, until lead is removed. Once the barrel is lead free, run an oily patch down the bore. Use a non-jointed cleaning rod if possible.

Use of cleaning solvents and agents formulated for firearms can damage the seals and O-rings, rendering the rifle inoperative. Be careful to only get lead remover solvents in the barrel. Remove any excess solvents immediately.

Removing jammed projectiles from the barrel

Remove the air tank. Always attempt to remove jammed projectiles from the breech through the muzzle; only go from the muzzle end if there is no other way. Use a good cleaning rod of the correct size to push the jam out of the muzzle.

Note: If a projectile gets stuck in the barrel because the pressure in the air tank gets too low, it may be possible to refill your air tank, and then shoot the projectile out.

DO NOT LOAD ANOTHER PROJECTILE UNTIL THE JAMMED PROJECTILE IS REMOVED.



**WARNING: ALWAYS KEEP THE MUZZLE
POINTED IN A SAFE DIRECTION**

Maintenance of the Air Tank and Care During Storage

AirForce airguns have an air tank pressurized to 3,000 psi or 3625 psi (depending on the tank's individual pressure rating) when full. This tank is designed to be filled at all times. You can leave it fully pressurized indefinitely or you can keep a lower "caretaker" charge of around 2,000 psi in the tank, if you desire.

The air tank is equipped with a safety burst disk that will rupture if the internal pressure gets too high. Under no circumstances should the tank be pressurized beyond the recommended fill pressure specified on the tank.

NOTICE: READ THIS MANUAL ENTIRELY BEFORE CHARGING OR USING YOUR AIRGUN

Safe Shooting

The AirForce Texan is extremely powerful and should always be used with a safe backstop. A firearm bullet trap rated for 800 ft. lbs. of energy or greater is required.

Never point the muzzle of the rifle at anything you do not intend to shoot. Make this a habit, so you handle an empty airgun the same way all the time. If you handle all guns this way, you will protect yourself and others if there should be an accidental discharge at any time.

Lead projectiles from all AirForce airguns will explode into dust and fragments when they hit a hard surface like a steel backer plate in a bullet trap. Always wear safety glasses when shooting into a hard bullet trap.

In the field, avoid targets that will cause the projectile to ricochet. These can be both hard targets like plywood, trees, the sides of structures, water, snow, ice or the ground when struck at a shallow angle.



**WARNING: ALWAYS KEEP THE MUZZLE
POINTED IN A SAFE DIRECTION**

Troubleshooting

Gun fails to fire when the trigger is pulled

Is the gun cocked?

Has the safety been taken off?

Is the removable air tank installed?

Is the tank filled with air?

Is anything blocking the valve or the bolt?

Is the air tank overfilled, causing valve lock?

Air is leaking from the tank

Install the air tank on the rifle and fire several times without a projectile. Be sure there is at least 2000 psi in the tank. If air continues to leak after this has been tried, it will have to be repaired at the factory.

Gun fires but projectile remains in the barrel

Is the air tank filled?

Is the barrel free from obstructions?

Was the action closed and locked when you fired?

Is the projectile of the correct caliber for the barrel?

Are you sure the projectile did not exit the barrel? Remove the air tank and look through the rear of the barrel to verify that it is still inside.

Is the tuner turned up high enough for the specific projectile? If the tuner is turned down, increase its tension on the striker spring by rotating it downward. Once you get the gun to fire, you can start backing the tuner down again to the desired level.

Gun fires with widely varying velocity

Are all the projectiles the same?

Are the projectiles high quality?

Are you using lead projectiles? Synthetic projectiles deposit residue in the barrel that can cause velocity variation.

Are the projectiles the correct caliber?

Is the air tank filled to 3,000 psi? As the tank drops to 2,000 psi, velocity will start to vary more.

Is the barrel dirty?

NOTICE: READ THIS MANUAL ENTIRELY BEFORE CHARGING OR USING YOUR AIRGUN

Troubleshooting

Air leaks from the refill clamp when filling the air tank

Is the refill clamp bleed valve closed?

Is the refill clamp thumbscrew hand-tight?

Is the O-Ring present on the K-Valve face?

(For refill tanks utilizing a K-Valve, an O-Ring should be present on the valve face.

For refill tanks utilizing a DIN-Valve, an O-Ring should be present on the refill assembly.)

The hand pump doesn't seem to fill the air tank

Is the brass bleed screw on the pump base closed?

It can be difficult to determine that the hand pump is filling the air tank when the tank is empty. An empty air tank doesn't SEEM to be filling when you pump the pump. Actually it takes about 75 pump strokes before you notice that the needle on the pump's gauge is slightly above zero. Once the tanks starts to register a charge, you will notice that it takes 14 or 15 pump strokes to raise the tank pressure by 100 psi. That's true at all pressure levels.



**WARNING: ALWAYS KEEP THE MUZZLE
POINTED IN A SAFE DIRECTION**

AirForce Warranty for Airguns Sold in the United States

Mailing the enclosed warranty card within 60 days of purchase entitles the original buyer to a warranty covering defects in material and workmanship for the life of the airgun. Any AirForce airgun covered by this warranty will be repaired or replaced at the discretion of AirForce, should a defect in material or workmanship be found.

Normal wear parts such as O-rings and seals, are not covered.

Repairs may only be made by the factory or an authorized service station. This lifetime warranty becomes invalid for any gun that is disassembled or modified in any way not specifically authorized by the factory. This lifetime warranty also becomes invalid for any gun that has been damaged by abuse or improper handling.

For shipping instructions for warranty service call 1-877-247-4867. This warranty is not valid for guns used in governmental or commercial applications. A one-year warranty applies in those instances.

**NOTICE: READ THIS MANUAL ENTIRELY BEFORE
CHARGING OR USING YOUR AIRGUN**



www.airforceairguns.com

877-247-4867 • 817-451-8966 • (fax) 817-451-1613

P.O. Box 2478 • Fort Worth, TX 76113

*Photographs, drawings, descriptions and other information are purely indicative.
AirForce reserves the right to change, modify or discontinue products or features at any time.*

Rev. 08/20